

From: <http://www.sciencemadesimple.com/static.html>

## What is Static Electricity?

You walk across the rug, reach for the doorknob and.....ZAP!!!  
You get a static shock.

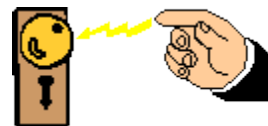

Or, you come inside from the cold, pull off your hat and.....static hair!!  
The static electricity makes your hair stand straight out from your head.

What is going on here? And why is static more of a problem in the winter?

To understand static electricity, we have to learn a little bit about the nature of matter.  
Or in other words, what is all the stuff around us made of?

Imagine a pure gold ring. Divide it in half and give one of the halves away. Keep dividing and dividing and dividing. Soon you will have a piece so small you will not be able to see it without a microscope. It may be very, very small, but it is still a piece of gold.



If you could keep dividing it into smaller and smaller pieces, you would finally get to the smallest piece of gold possible. It is called an atom. If you divided it into smaller pieces, it would no longer be gold.

Everything around us is made of atoms and scientists so far know of 118 different kinds. These different kinds of atoms are called "elements." There are 98 elements that exist naturally (although some are only found in very small amounts). Four of these 118 elements have reportedly been discovered, but have not yet been confirmed.

Atoms join together in many different combinations to form molecules, and create all of the materials you see around you.

### Parts Of An Atom

So what are atoms made of? In the middle of each atom is a "nucleus." The nucleus contains two kinds of tiny particles, called protons and neutrons. Orbiting around the nucleus are even smaller particles called electrons. The 115 kinds of atoms are different from each other because they have different numbers of protons, neutrons and electrons.

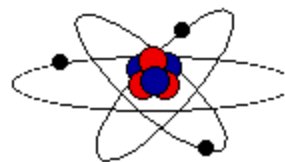

It is useful to think of a model of the atom as similar to the solar system. The nucleus is in the center of the atom, like the sun in the center of the solar system. The electrons orbit around the nucleus like the planets around the sun.

Just like in the solar system, the nucleus is large compared to the electrons. The atom is mostly empty space. And the electrons are very far away from the nucleus. While this model is not completely accurate, we can use it to help us understand static electricity.

(Note: A more accurate model would show the electrons moving in 3- dimensional volumes with different shapes, called orbitals. This may be discussed in a future issue.)

## **Electrical Charges**

Protons, neutrons and electrons are very different from each other. They have their own properties, or characteristics. One of these properties is called an electrical charge. Protons have what we call a "positive" (+) charge. Electrons have a "negative" (-) charge. Neutrons have no charge, they are neutral.

The charge of one proton is equal in strength to the charge of one electron. When the number of protons in an atom equals the number of electrons, the atom itself has no overall charge, it is neutral.

## **Electrons Can Move**

The protons and neutrons in the nucleus are held together very tightly. Normally the nucleus does not change. But some of the outer electrons are held very loosely. They can move from one atom to another.

An atom that loses electrons has more positive charges (protons) than negative charges (electrons). It is positively charged. An atom that gains electrons has more negative than positive particles. It has a negative charge. A charged atom is called an "ion."

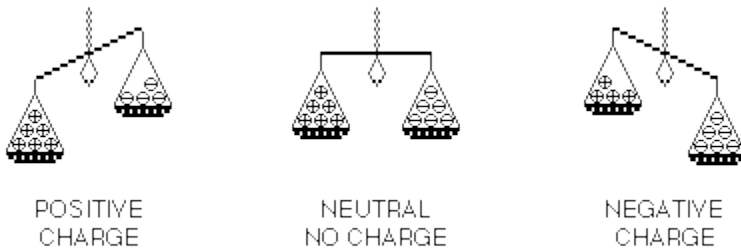

Some materials hold their electrons very tightly. Electrons do not move through them very well. These things are called insulators. Plastic, cloth, glass and dry air are good insulators. Other materials have some loosely held electrons, which move through them very easily. These are called conductors. Most metals are good conductors.

How can we move electrons from one place to another? One very common way is to rub two objects together. If they are made of different materials, and are both insulators, electrons may be transferred (or moved) from one to the other. The more rubbing, the more electrons move, and the larger the static charge that builds up. (Scientists believe that it is not the rubbing or friction that causes electrons to move. It is simply the contact

between two different materials. Rubbing just increases the contact area between them.)

**Static electricity is the imbalance of positive and negative charges.**

## Opposites Attract

Now, positive and negative charges behave in interesting ways. Did you ever hear the saying that opposites attract? Well, it's true. Two things with opposite, or different charges (a positive and a negative) will attract, or pull towards each other. Things with the same charge (two positives or two negatives) will repel, or push away from each other.

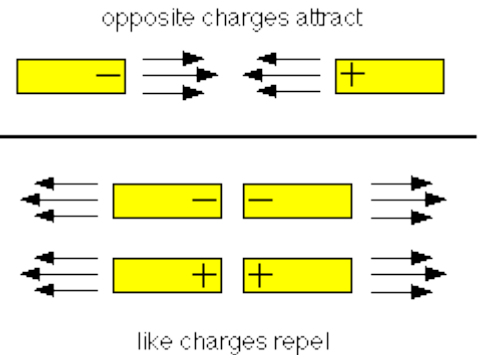

A charged object will also attract something that is neutral. Think about how you can make a balloon stick to the wall.

If you charge a balloon by rubbing it on your hair, it picks up extra electrons and has a negative charge. Holding it near a neutral object will make the charges in that object move.

If it is a conductor, many electrons move easily to the other side, as far from the balloon as possible.

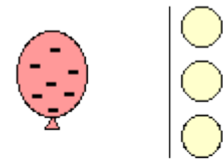

If it is an insulator, the electrons in the atoms and molecules can only move very slightly to one side, away from the balloon.

In either case, there are more positive charges closer to the negative balloon.

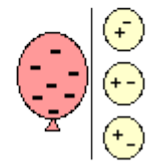

Opposites attract. The balloon sticks. (At least until the electrons on the balloon slowly leak off.) It works the same way for neutral and positively charged objects.

So what does all this have to do with static shocks? Or static electricity in hair?

When you take off your wool hat, it rubs against your hair. Electrons move from your hair to the hat. A static charge builds up and now each of the hairs has the same positive charge.

Remember, things with the same charge repel each other. So the hairs try to get as far from each other as possible. The farthest they can get is by standing up and away from the others. And that is how static electricity causes a bad hair day.